

Equivalent of Heat Apparatus Copper Cylinder

1002658 / U10365

1002659 / U10366

Instruction Sheet

10/11 MH/ALF

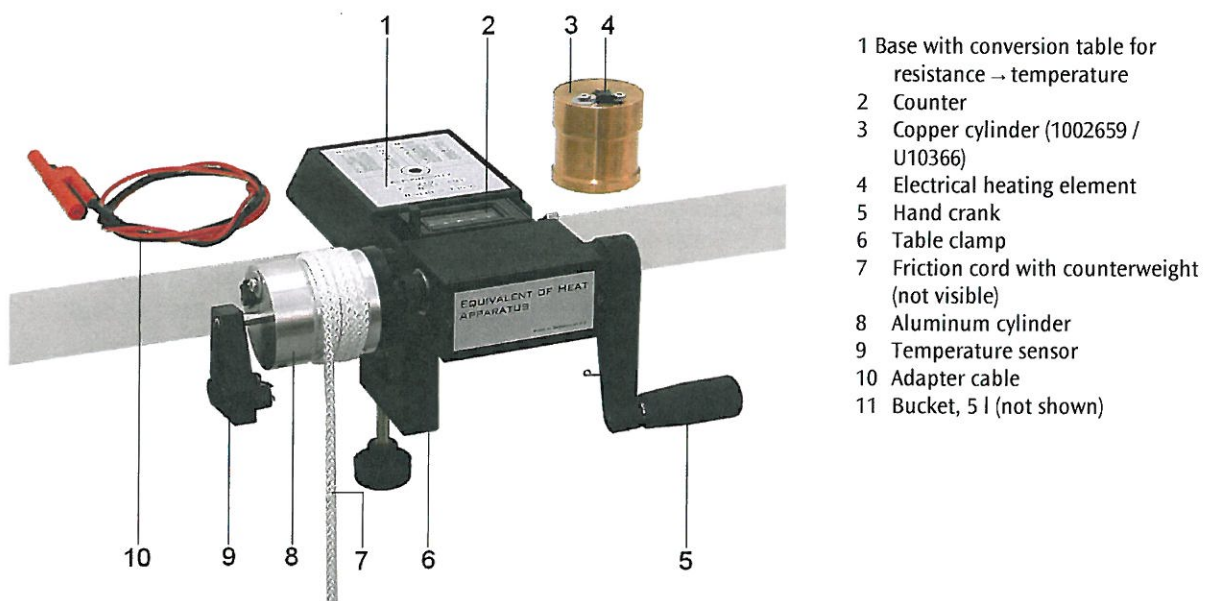

Fig.1: Components

1. Safety instructions

Risk of injury! The (approx. 5 g) weight attached to the cord (7) can cause injury to persons if it falls on them.

- It should be placed on the ground to secure it and not be raised more than about 10 cm during the experiment.

Risk of burning! During the experiments the friction cylinder (3 or 8) is heated.

- It should be observed that the temperature does not rise above about 40°C. The maximum permissible

current through the heating element is 3 A and may not be exceeded.

Risk of electric shock!

- The maximum output voltage of the power supply used for the electric heating may not be greater than 40 V

2. Description,

The equivalent of heat apparatus can be used to show the equivalence of mechanical work due to friction (Nm), electrical energy (Ws) and heat (J). The values measured in Nm or Ws agree to an accuracy of about 2%. If this equivalence is assumed, the specific heat capacity of aluminium and copper can be determined. The stable design with its integrated rotary counter and a dual ball-bearing mounted shaft make experiments as simple as possible to perform. To measure temperature a negative temperature coefficient thermistor (NTC) is used. This is safely contained inside an aluminium sleeve. The aluminium sleeve snaps into the friction cylinder so that it cannot slide out unintentionally.

3. Technical data

Technical data for the friction cylinder (approximate values):

Diameter D :	48 mm
Height:	50 mm
Aluminum cylinder:	mass $m_A = 250$ g, specific heat capacity $c_A = 0,86$ kJ/kg K,
Copper cylinder:	$m_k = 750$ g, $c_k = 0,41$ kJ/kg K
Electrical connection:	sockets of 2 mm diameter, positive pole “+” isolated, negative pole “-” connected to ground, reversal of polarity does not destroy the equip- ment

4. Operation

- The equivalent of heat apparatus is attached to a stable workbench using its table clamp. The friction cord is then wrapped around the friction cylinder $4\frac{1}{2}$ to $5\frac{1}{2}$ times with the counterweight suspended at the rear and the loose end of the cord hanging down at the front.
- The bucket provided can be filled with water or sand etc. (total weight approx. 5 kg) and used as a weight. The loose end of the friction cord is attached to the weight while the latter is resting on the ground. It should be observed that the counterweight should be no more than about 5 cm above the ground when the cord is taut. This prevents the weight being raised by more than about 10 cm during the experiment.
- If it is observed that the cord moves to the right when the crank is turned or fails to remain in its groove, then the cord should be wrapped around the cylinder so that the end of the cord with the

weight is on the right and that with the counterweight is on the left.

- The temperature sensor should be wetted with a drop of oil (important!) and inserted into the selected friction cylinder according to Fig. 1 until it is felt to snap into place and can be turned easily (if it is inserted too far or not far enough, it is not easy to turn it). The two connections of the temperature sensor are attached to a resistance meter (multimeter) operating in the range $2\text{ k}\Omega$ to $9\text{ k}\Omega$ with a display accurate to at least three figures. The conversion of the resistance so measured into a corresponding temperature can be performed either with the help of the conversion table on the last page of these instructions or by using the following equation:

$$T = \frac{217}{R^{0,13}} - 151 \quad (1)$$

where R must be given in $\text{k}\Omega$ to obtain T in $^\circ\text{C}$. This equation agrees with the table provided by the NTC thermistor manufacturer in the range from $10 - 40^\circ\text{C}$ to an accuracy of approximately $\pm 0.05^\circ\text{C}$.

- Before an experiment the friction cylinder should be cooled to about $5 - 10^\circ\text{C}$ below the ambient temperature. This can be achieved by putting it in a refrigerator or by dipping it in cold water. In the latter case the hole for the temperature sensor should point upwards and the cylinder may only be immersed to a depth of about $2/3$ the height of the cylinder (tip: if the friction cylinder is dipped in water inside a plastic bag, it will not need to be dried off again when it has finished cooling).
- The rise in temperature during an experiment should continue until the friction cylinder's temperature has been raised to about $5 - 10^\circ\text{C}$ above the ambient temperature. The more precisely the temperature differences for cooling and heating (with respect to the ambient temperature) are similar, then the smaller is the net exchange of heat with the environment.
- For heating the friction cylinder electrically, adapter cables are provided with plugs of 2 mm diameter at one end and conventional 4 mm lab plugs at the other. The power should be provided by a power supply where voltage and current limiting can be regulated. The maximum voltage from the power supply may not exceed 40 V. The positive pole of the power supply is connected to the isolated socket (identifiable due to the round, gray plate beneath the socket) and the negative is connected to the other socket.
- The heating filaments on the friction cylinders behave more or less like normal ohmic resistors with a resistance of about $11\ \Omega$. Their maximum load capacity is about 36 W, i.e. for a max. voltage of 20 V

and corresponding current of roughly 1.8 A. To set an operating point, it is recommended that the current limit be set to exactly 1 A with voltage limited to about 15 V. These settings cannot be altered thereafter. Power is disconnected simply by removing the power lead until needed for the experiment.

5. Maintenance

- The equivalent of heat apparatus in principle requires no maintenance. It can be wiped clean with soap and water. Solvents should not be used. Immersion in water should also be avoided.
- The friction cylinders should be plain naked metal. If a coating has formed on them, this can be removed using metal cleaner.
- The friction cord can be washed if necessary. For a good value alternative, woven nylon cord can be used as a replacement.

6. Experiment procedure and evaluation

6.1 Conversion of mechanical work into heat

6.1.1 Experiment procedure

- First the various masses are measured:
Primary weight (e.g. bucket with water) $m_u = 5.22$ kg
Counterweight (at friction cord) $m_c = 0.019$ kg
Aluminium cylinder $m_A = 0.249$ kg
- Other values to be measured in advance:
Ambient temperature $T_u = 23.2^\circ\text{C}$
Diameter of cylinder where friction occurs $D_R = 45.75$ mm
- After cooling the cylinder, it should be screwed to the base, the temperature sensor should be inserted and the friction cord should be wrapped around it. (cf. Section 4). After a few minutes, that should be ignored for the sake of a homogenous temperature distribution, the resistance of the temperature sensor is $R_1 = 8,00$ k Ω (corresponding to $T_1 = 14,60^\circ\text{C}$ by Eq.1).
- After zeroing the counter, the experiment is begun by turning the crank and thus lifting the primary weight from the ground. This slightly loosens the cord so that it causes less friction on the cylinder. The primary weight remains at the same height and should remain there for the rest of the experiment.
- After $n = 460$ turns the experiment is halted and the resistance value read off: $R_2 = 3.99$ k Ω ($T_2 = 30.26^\circ\text{C}$). Since the temperature continues to rise for a short time after the experiment is completed (homogenizing the temperature distribution), the minimum value of the resistance is noted as the measured

value. This is reached a few seconds after the end of the experiment. After that the resistance increases again since heat is exchanged with the environment to cool the cylinder down to a lower temperature.

6.1.2 Experiment evaluation

Work W is defined as the product of force F and displacement s

$$W = F \cdot s \quad (2)$$

The force of friction acting is

$$F = m_A \cdot g \quad (3)$$

(g is the acceleration due to gravity) in the direction of the displacement

$$s = n \cdot \pi \cdot D_R \quad (4)$$

- Placing Equations 3 and 4 into Equation 2 gives:

$$W = m_A \cdot g \cdot n \cdot \pi \cdot D_R = 5.22 \cdot 9.81 \cdot 460 \cdot 3.1416 \cdot 0,04575 = 3386 \text{ Nm} \quad (5)$$

The heat stored in the friction cylinder ΔQ is determined from the temperature difference ($T_2 - T_1$) and the specific heat capacity given in Section 3:

$$\Delta Q = c_A \cdot m_A \cdot (T_2 - T_1) = 0.86 \cdot 0.249 \cdot (30.26 - 14.60) \text{ kJ} = 3353 \text{ J} \quad (6)$$

In this example the disagreement between the mechanical work and the heat energy is found to be no more than about 1%. Due to unavoidable tolerances relating to the composition of materials (aluminium is very soft and almost impossible to work mechanically, so that it is always alloyed), the specific heat capacity can fluctuate quite noticeably. The specific heat capacity is most easily calculated by heating it electrically using the equivalence between heat and electrical energy.

6.2 Conversion of electrical energy into heat

6.2.1 Experiment procedure

- After cooling the friction cylinder it should be screwed into the base (the same experimental conditions as for the friction experiment) and the temperature sensor inserted. After a few minutes that should be ignored for the sake of homogenous distribution of temperature, the resistance of the temperature sensor is $R_1 = 8.00$ k Ω (corresponding to $T_1 = 14.60^\circ\text{C}$ by Eq. 1).
- Now the power supply that has been configured in advance (see Section 4) should be connected to the heating element and a stopwatch started. Voltage and current (as displayed by the power supply) should be noted:
 $U = 11.4$ V; $I = 1.0$ A
- After $t = 300$ s the experiment is halted and the resistance of the sensor is read off:
 $R_2 = 3.98$ k Ω ($T_2 = 30.32^\circ\text{C}$)

The (slight) change in voltage is also measured:
 $U = 11.0 \text{ V}$.

6.2.2 Experiment evaluation

The electrical energy E is the product of power P and time t . The power is the product of voltage and current. Therefore (using average voltage for the calculation):

$$E = U \cdot I \cdot t = 11.2 \cdot 1.0 \cdot 300 = 3360 \text{ Ws} \quad (7)$$

In this experiment, the heat added is

$$\Delta Q = c_A \cdot m_A \cdot (T_2 - T_1) = 0.86 \cdot 0.249 \cdot (30.32 - 14.60) \text{ KJ} = 3366 \text{ J} \quad (8)$$

The agreement between E and ΔQ is very good in this instance as well.

Relationship between resistance and temperature of the temperature sensor

$R / \text{k}\Omega$	$T / ^\circ\text{C}$	$R / \text{k}\Omega$	$T / ^\circ\text{C}$	$R / \text{k}\Omega$	$T / ^\circ\text{C}$	$R / \text{k}\Omega$	$T / ^\circ\text{C}$	$R / \text{k}\Omega$	$T / ^\circ\text{C}$
7.86	14.97	6.78	18.19	5.70	22.05	4.62	26.84	3.54	33.10
7.84	15.03	6.76	18.26	5.68	22.13	4.60	26.94	3.52	33.24
7.82	15.08	6.74	18.32	5.66	22.21	4.58	27.04	3.50	33.38
7.80	15.14	6.72	18.39	5.64	22.29	4.56	27.14	3.48	33.51
7.78	15.19	6.70	18.45	5.62	22.37	4.54	27.24	3.46	33.65
7.76	15.25	6.68	18.52	5.60	22.45	4.52	27.35	3.44	33.79
7.74	15.31	6.66	18.58	5.58	22.53	4.50	27.45	3.42	33.93
7.72	15.36	6.64	18.65	5.56	22.61	4.48	27.55	3.40	34.07
7.70	15.42	6.62	18.72	5.54	22.69	4.46	27.66	3.38	34.22
7.68	15.47	6.60	18.78	5.52	22.77	4.44	27.76	3.36	34.36
7.66	15.53	6.58	18.85	5.50	22.85	4.42	27.87	3.34	34.50
7.64	15.59	6.56	18.92	5.48	22.94	4.40	27.97	3.32	34.65
7.62	15.64	6.54	18.99	5.46	23.02	4.38	28.08	3.30	34.79
7.60	15.70	6.52	19.05	5.44	23.10	4.36	28.18	3.28	34.94
7.58	15.76	6.50	19.12	5.42	23.19	4.34	28.29	3.26	35.09
7.56	15.81	6.48	19.19	5.40	23.27	4.32	28.40	3.24	35.24
7.54	15.87	6.46	19.26	5.38	23.35	4.30	28.51	3.22	35.39
7.52	15.93	6.44	19.33	5.36	23.44	4.28	28.62	3.20	35.54
7.50	15.99	6.42	19.40	5.34	23.52	4.26	28.72	3.18	35.69
7.48	16.05	6.40	19.46	5.32	23.61	4.24	28.83	3.16	35.84
7.46	16.10	6.38	19.53	5.30	23.69	4.22	28.95	3.14	36.00
7.44	16.16	6.36	19.60	5.28	23.78	4.20	29.06	3.12	36.15
7.42	16.22	6.34	19.67	5.26	23.87	4.18	29.17	3.10	36.31
7.40	16.28	6.32	19.74	5.24	23.95	4.16	29.28	3.08	36.47
7.38	16.34	6.30	19.81	5.22	24.04	4.14	29.39	3.06	36.63
7.36	16.40	6.28	19.88	5.20	24.13	4.12	29.51	3.04	36.79
7.34	16.46	6.26	19.95	5.18	24.21	4.10	29.62	3.02	36.95
7.32	16.52	6.24	20.03	5.16	24.30	4.08	29.74	3.00	37.11
7.30	16.57	6.22	20.10	5.14	24.39	4.06	29.85	2.98	37.28
7.28	16.63	6.20	20.17	5.12	24.48	4.04	29.97	2.96	37.44
7.26	16.69	6.18	20.24	5.10	24.57	4.02	30.09	2.94	37.61
7.24	16.75	6.16	20.31	5.08	24.66	4.00	30.20	2.92	37.78
7.22	16.81	6.14	20.39	5.06	24.75	3.98	30.32	2.90	37.94
7.20	16.88	6.12	20.46	5.04	24.84	3.96	30.44	2.88	38.11
7.18	16.94	6.10	20.53	5.02	24.93	3.94	30.56	2.86	38.29
7.16	17.00	6.08	20.60	5.00	25.02	3.92	30.68	2.84	38.46
7.14	17.06	6.06	20.68	4.98	25.11	3.90	30.80	2.82	38.63
7.12	17.12	6.04	20.75	4.96	25.21	3.88	30.92	2.80	38.81
7.10	17.18	6.02	20.83	4.94	25.30	3.86	31.04	2.78	38.99
7.08	17.24	6.00	20.90	4.92	25.39	3.84	31.17	2.76	39.17
7.06	17.30	5.98	20.97	4.90	25.48	3.82	31.29	2.74	39.35
7.04	17.37	5.96	21.05	4.88	25.58	3.80	31.42	2.72	39.53

7.02	17.43	5.94	21.12	4.86	25.67	3.78	31.54	2.70	39.71
7.00	17.49	5.92	21.20	4.84	25.77	3.76	31.67	2.68	39.90
6.98	17.55	5.90	21.28	4.82	25.86	3.74	31.79	2.66	40.08
6.96	17.62	5.88	21.35	4.80	25.96	3.72	31.92	2.64	40.27
6.94	17.68	5.86	21.43	4.78	26.05	3.70	32.05	2.62	40.46
6.92	17.74	5.84	21.50	4.76	26.15	3.68	32.18	2.60	40.65
6.90	17.81	5.82	21.58	4.74	26.25	3.66	32.31	2.58	40.84
6.88	17.87	5.80	21.66	4.72	26.34	3.64	32.44	2.56	41.04
6.86	17.93	5.78	21.74	4.70	26.44	3.62	32.57	2.54	41.23
6.84	18.00	5.76	21.81	4.68	26.54	3.60	32.70	2.52	41.43
6.82	18.06	5.74	21.89	4.66	26.64	3.58	32.84	2.50	41.63
6.80	18.13	5.72	21.97	4.64	26.74	3.56	32.97	2.48	41.83

